



Critical Minerals to
Energy Storage

DISCLAIMER

This Investor Presentation is not to be considered an offer to sell, or a solicitation of an offer to buy, securities, as such offerings may only be made by way of exemptions from prospectus requirements and only in those jurisdictions where such securities may be lawfully offered for sale. Any such offer to sell or solicitation of an offer to buy the securities described herein or during the presentation will be made only pursuant to subscription documentation. This Investor Presentation is for information purposes only and does not, and under no circumstances is it to be construed as, a prospectus, advertisement or an offer to sell or a solicitation to buy a security. No securities commission or similar regulatory authority has passed on the merits of the securities offered nor has it reviewed this Investor Presentation. The information contained herein, while obtained from sources believed to be reliable, is not guaranteed as to its accuracy or completeness.

FORWARD LOOKING INFORMATION

In the interests of providing prospective investors with information regarding Volt Carbon Technologies Inc. (the “Company”), including management’s assessment of future plans and operations relating to the Company and industry outlook, this Investor Presentation contains certain statements and information that are forward-looking statements or information within the meaning of applicable securities legislation, and which are collectively referred to herein as “forward looking statements”. When used in this document, the words “may”, “would”, “could”, “will”, “intend”, “plan”, “anticipate”, “believe”, “seek”, “propose”, “estimate”, “expect” and similar expressions, as they relate to the Company, often, but not always, identify forward-looking statements. Such statements reflect the Company’s views at the time such statements are made with respect to future events and are subject to certain risks, uncertainties and assumptions. All forward-looking statements in this document are expressly qualified by this disclaimer and cautionary statement. Other than as required by applicable securities laws, the Company assumes no obligation to update forward-looking statements should circumstances or the Company’s estimates or opinions change.

Forward-looking statements in this document include, but are not limited to statements (collectively “forward-looking statements”) with respect to: the anticipated development and commercialization of proprietary air classifier technology for mineral separation; the predicted advancement of critical mineral property interest towards sustainable recovery using the Air Classifier Technology; the future supply of carbon products including Flake Graphite, Battery Anodes and Graphene; the future development and anticipated Commercialization of proprietary Lithium Metal battery Technology; the potential mass-market applications of the technology including automotive, aerospace, and consumer electronics; the anticipated commercial application of sustainable mineral separation with low cost environmentally responses process with the predicted with limited risk of acid drainage and zero wet tailings; the expected rise of global lithium-ion battery capacity to 2800 GWh by 2030; the expected rise of demand for graphite to rise to 4.5mt by 2050; the expected rise of graphite demand for energy store alone is expected to be 3mt in a 4mt market by 2030; management’s belief that the air classification process can be used for extracting flake graphite from aggregate in a quarry type setting; the anticipated graphite purification of up to 95%; managements believe that Volt’s SSBs have a lower carbon foot print, higher recyclability, and reduced manufacturing complexity; managements belief that 350Wh/kg of energy density with 500 cycles will be achieved by 2023; anticipated ability to profit from the sale of sand byproducts produced from the air classification (dry circuit) process, anticipated ability of the company’s battery technology to compete with and disrupt the current technologies in the automotive, aerospace and consumer electronics industries, anticipated increase demand in graphite and increased use energy storage; anticipated global lithium battery capacity forecast; expected increased adoption of battery-electric vehicles; anticipated supply risks for graphite based on current and projected locations of graphite production; continued purity, energy use, carbon intensity, logistical complexity and by-products from flotation (wet circuit) beneficiation methods; anticipated charge rate, cycle life, energy use and cost of competing batteries; anticipated future timeline and milestones for the Company; anticipated use of Company’s technology for aerospace applications and the development of solar-electric aircraft using the Company’s Solid Ultrabattery technology; the planned testing with consumer products by September 2023; the planned development of multi-lawyers cells by 2024; and the planned production facilities in place to manufacture batteries by 2027; and anticipated ability of the Company’s Solid Ultrabattery pouch cells to extend endurance of solar electric test aircrafts by 50%; management’s belief that the Company’s air classification technology promises a bright future and can substantially lower production costs and reduce many of the adverse impacts; management’s belief that the technology is capable of substantially reducing costs and carbon footprint of extracting flake graphite using a dry circuit; and management’s belief that that lithium metal batter technology is competitive with the larges companies in this space .

Readers are cautioned not to place undue reliance on forward-looking statements, as there can be no assurance that the plans, intentions or expectations upon which they are based will occur. By their nature, forward-looking statements involve numerous assumptions, as well as known and unknown risks and uncertainties, both general and specific, that contribute to the possibility that the predictions, forecasts, projections and other forward-looking statements will not occur and which may cause the Company’s actual performance and financial results in future periods to differ materially from any estimates or projections of future performance or results expressed or implied by the forward-looking statements. These assumptions, risks and uncertainties include, among other things: the continued demand for sand by products, the current and continued state of battery technology used in the automotive, aerospace and consumer electronics sector; the accuracy of the NI 43-101 technical report completed by SRK consulting in 2015 for the entire property for public issuer Great Lakes Graphite Inc and the flake graphite potential of the company’s Lochaber, Quebec property; and the companies continued access to resources and retention of the appropriate academic commercialize its battery products and anticipated increase demand in graphite and increased use energy storage; the ability to replicate results, measurements, and estimates achieved in laboratory environments on a commercial scale; the ability for a third party to verify the results, measurements and estimated achieved in laboratory environments; anticipated global lithium battery capacity forecast; expected increased adoption of battery-electric vehicles globally; anticipated supply risks for graphite based on current and projected locations of graphite production; continued advantage of air classification (dry circuit) beneficiation methods compared to flotation (wet circuit) related to purity, energy use, Carbon intensity, logistical complexity and by-products; continued advantages of the Company’s Solid Ultrabattery compared to its leading competitor based on charge rate, cycle life, energy use and cost; Company’s ability to meet its desired timeline and milestones; ability to use Company’s technology for aerospace applications; development of successful solar-electric aircraft with Company’s Solid Ultrabattery technology; anticipated extension of ensure for drones from Company’s Solid Ultrabattery technology; estimates regarding timing of future development, construction, production or closure activities; and statements regarding cost structure, project economics, or competitive position; the ability of the Company to scale up its current laboratory results and pilot operations into a large scale commercial utilization in a cost-effective and efficient manner; the Company’s ability to gain from economies of scall through the development of additional technologies and batteries; stability in laws or regulations or the interpretations of such laws or regulations; the continuation of operating risks inherent in the novel lithium extraction industry; the adequacy and availability of pre-existing subsurface and resource data for extraction target areas and the reliability of the available historical data; the anticipated financial performance of the Company and cost of the development and establishment of the extraction plants; the Company’s ability to successfully implement strategic initiatives and whether such initiatives yield the expected benefits; the Company’s ability to access external sources of debt and equity capital; changes to tariffs and surcharges; and political and economic conditions.

Development and Commercialization of anticipated proprietary Air Classifier Technology for mineral separation

Future development and anticipated Commercialization of proprietary Lithium Metal Battery Technology¹

Predicted advancement of Critical Mineral property interests towards sustainable recovery using the Air Classifier Technology¹

Future supply of Carbon products including Flake Graphite, Battery Anodes and Graphene¹

Mineral Properties

- **A:** Quebec, Lochaber, graphite, 100% interest in 9 tenures at northern side of Plumbago Graphite Mine comprising of 540 hectares,
- **B:** British Columbia, Mount Copeland, molybdenum and critical minerals, 100% interest in 2 tenures comprising of 730 hectares
- **C:** British Columbia, Red Bird, molybdenum, copper and rhenium, 25% interest in 3 tenures comprising of 444 hectares
- **D:** Ontario, Manitouwadge graphite project, 128 mining claim cells covering 2662 hectares, claims overlap older legacy claims which were previously documented^{1,2,3,4} to contain graphite occurrences
- **E:** Abamasagi Lake Lithium Project, 150 mining claims covering 3100 hectares, grassroots property recommended by Ontario Ministry of Northern Development publication⁵. The area is in close proximity to 98th percentile deep sediment samplings of lithium and cesium anomalies in Abamasagi Lake⁵.

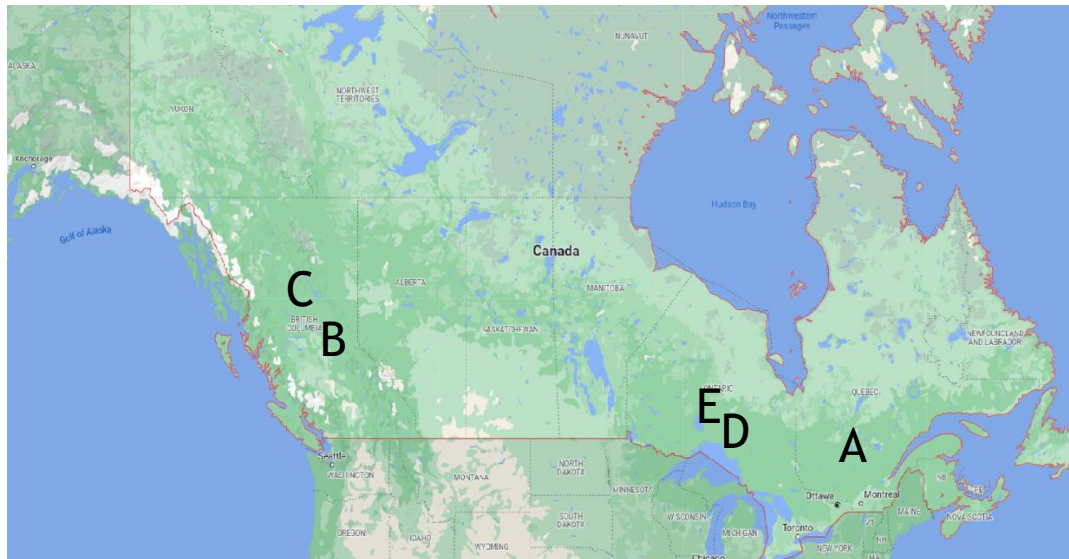

1, Ministry of Northern Development, Mines, Natural Resources and Forestry Recommendations for Exploration Special Edition: Critical Minerals Compilation 2020-2022,

2, McKay 1994. Mineral occurrences of the Manitouwadge area, volumes 1-3; Ontario Geological Survey, Open File Report 5906, 566p. 31112296

3, Ontario Mineral Inventory, MD1142F12SE00007, Taradale Graphite Occurrence - 1991

4, Technical Report on the Manitouwadge Graphite Exploration Property at Manitouwadge, Ontario, Canada. Felix, 2012

5, Ministry of Northern Development, Mines, Natural Resources and Forestry Recommendations for Exploration 2021-2022

Solid State Lithium Metal Battery Development



- Potential mass-market applications including automotive, aerospace, consumer electronics ¹
- Ontario-based battery prototyping facility commissioned in Dec 2021, partnered with University of Waterloo
- Proprietary Lithium Metal battery technology



¹ These statements are “forward looking information”. Please refer to the Forward Information Advisory on page two of this Presentation.

Sustainable Mineral Separation



- New Location located at Ontario, 2691 Markham Road, Scarborough (Nov 2022)
- Development facility for Mineral Separation with dry circuit
- Laboratory results indicate Graphite Separation using Air Classification achieves 85-95% purity ¹
- We anticipate low cost environmentally responsible processing with significantly reduced risk of acid drainage and zero wet tailings ²



Highlights 2022 FY

- ✓ Commissioned battery prototype facility (Guelph Location)
- ✓ Began to fabricate single & multi-layered pouch cells batteries in-house
- ✓ Reached 400 test cycles with Battery Cells fabricated at the Guelph Location
- ✓ 3 patent applications submitted (pending status): 2 for battery technology and 1 for air classifier method
- ✓ Completed two private placements 3.2M to fund expansion activities
- ✓ Successful laboratory testing of Air Classifier and validation of technology (achieved purity between 85 - 95% Cg)¹
- ✓ Took possession of new location in Scarborough and began to commission equipment to further develop graphite processing technology.
- ✓ Expanded board to include a mining executive

¹ Estimates and results are based on laboratory tests only and such results or estimates, as applicable, may not be replicated, scaled or result in the same estimates, measurements, or results in commercial utilizations. Estimates or results have not been verified by an independent third party and actual results may vary.

Anticipated Graphite Demand

- Lithium-ion batteries are typically 15% graphite by mass
 - A typical electric vehicle has approximately 50 kg of graphite within the batteries
- Global lithium-ion battery capacity was [450 GWh in 2020], and expected to rise to 2800 GWh by 2030¹
 - Driven largely by battery-electric vehicle adoption
- Demand for graphite is expected to rise to 4.5mt by 2050¹
 - An increase of ~500% over [2018 levels]
- Graphite demand for energy storage alone is expected to be 3mt in a 4mt market by 2030¹
 - [2017 demand was 200kt per year in an 800kt market]
- Concern of supply risks
 - [Over 60% of worldwide graphite production is concentrated in China]

Global Lithium Battery Capacity Forecast¹

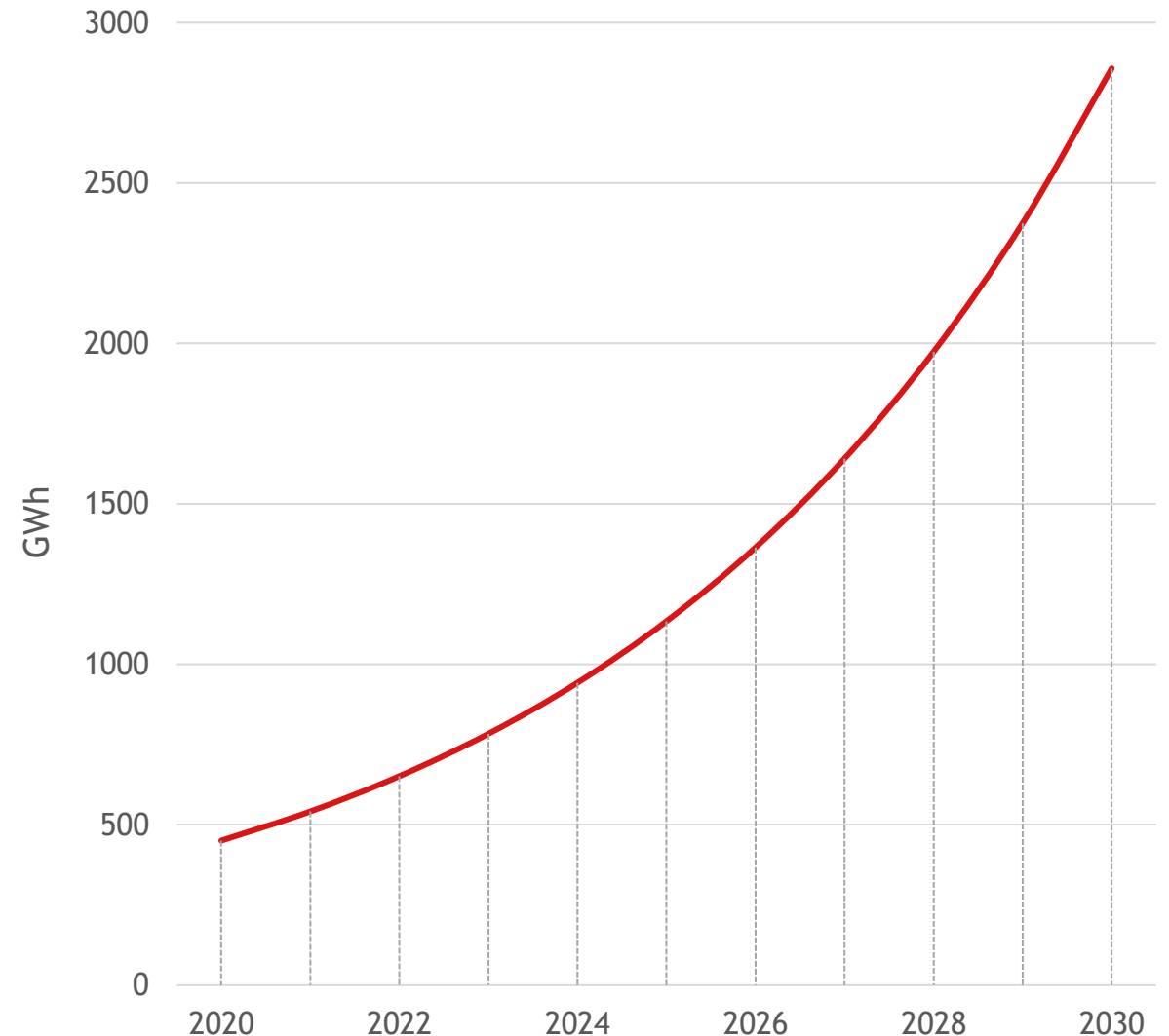



Synthetic vs. Natural Graphite

- Synthetic graphite is created by heating carbon-rich material to thousands of degrees for long periods of time
- Natural flake graphite is mined and purified
- Synthetic graphite is a large producer of GHG emissions
 - Synthesizing 1kg of graphite produces approximately 5kg CO₂-equivalent emissions
- We believe natural flake graphite will be a lower-cost alternative ¹
 - Increasing in popularity
 - Typically purified via floatation

¹ Estimates and results are based on laboratory tests only and such results or estimates, as applicable, may not be replicated, scaled or result in the same estimates, measurements, or results in commercial utilizations. Estimates or results have not been verified by an independent third party and actual results may vary.

¹ These statements are “forward looking information”. Please refer to the Forward Information Advisory on page two of this Presentation.

Flotation for Graphite Purification

- Natural graphite needs to be separated from mined ore
 - Battery-grade graphite must have high purity (>99%)
- This separation process is typically done through flotation & pyrometallurgical processes
- Flotation relies on chemical reagents to separate out the graphite
 - Flotation produces hazardous by-products such as wet tailings
- We believe environmental considerations are necessary for managing hazardous byproducts resulting from flotation¹

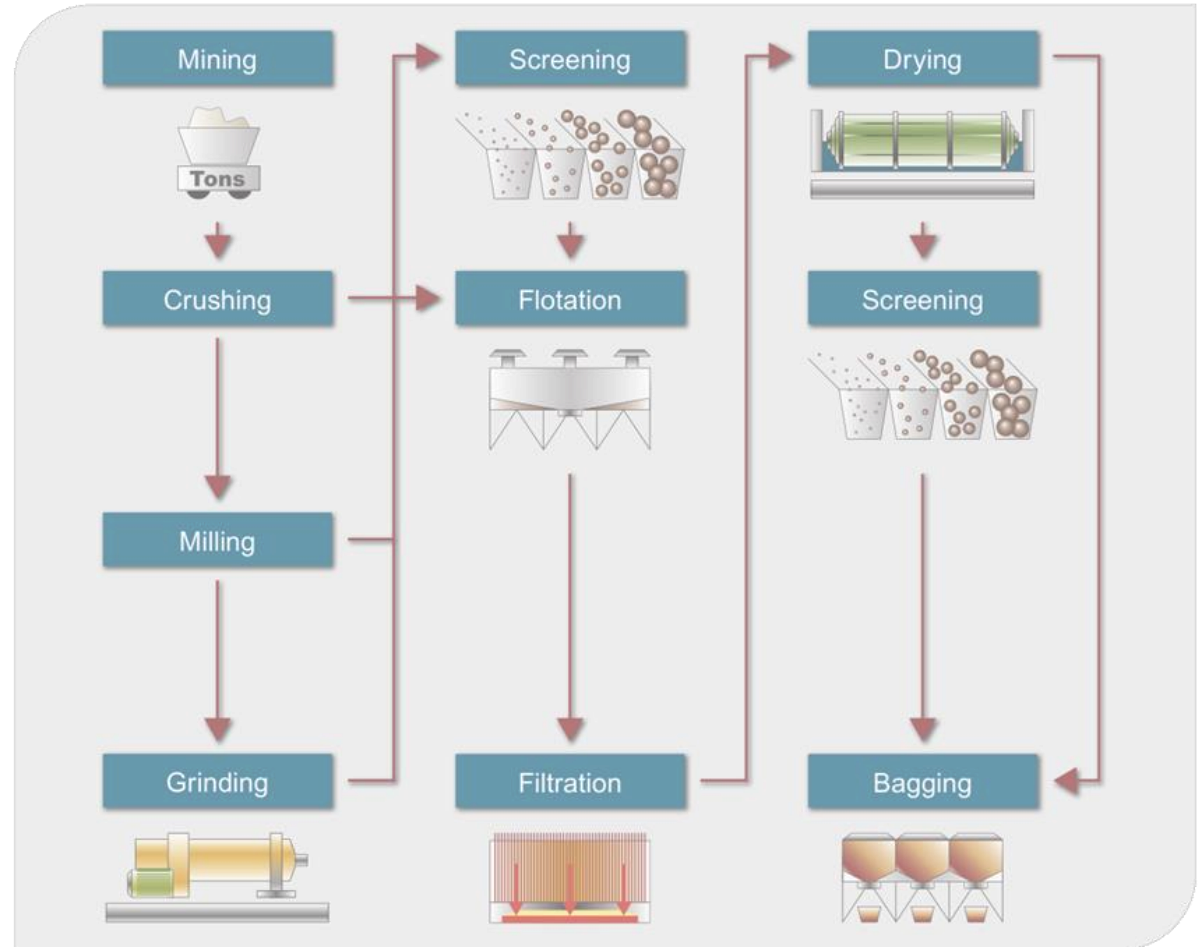
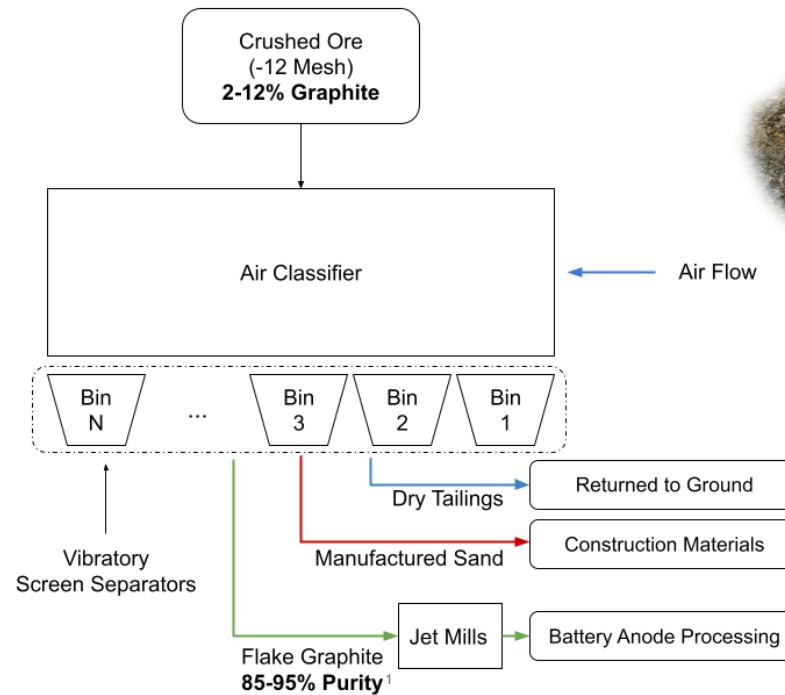

Image Source: Damm, S. and Zhou, Q.: Supply and Demand of Natural Graphite - DERA (2020)

Air Classification

Volt Carbon Technologies has what management believes is a potentially straightforward low energy proprietary air classification systems

- Graphite is liberated from host material using aerodynamics
- We believe this process can be used for extracting flake graphite from aggregate in a quarry type setting
- Graphite purification up to 95% purity depending on host material¹
- We believe this process can separate out graphite flakes from fine (<75µm) to super jumbo (>300µm) simultaneously¹
- Dry-circuit uses no reagents, acids or environmental contaminants
- Environmentally clean with what management believes is an efficient use of energy and water
- Serves as a primary purification process
- Management anticipates a substantial reduction in CAPEX compared to flotation for graphite purification²



Crushed Ore (-12 Mesh)

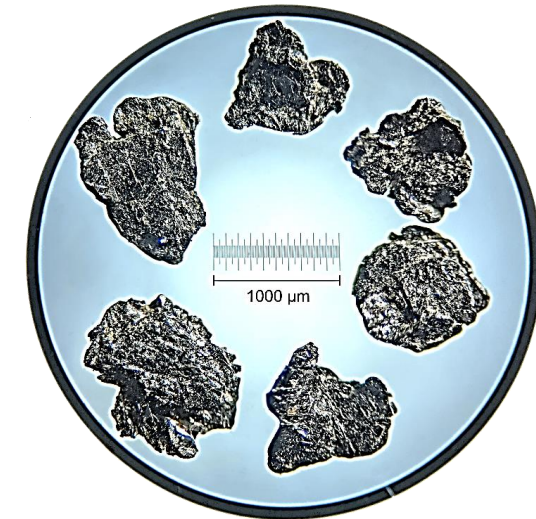











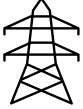





Flake Graphite Concentrate

¹ Estimates and results are based on laboratory tests only and such results or estimates, as applicable, may not be replicated, scaled or result in the same estimates, measurements, or results in commercial utilizations. Estimates or results have not been verified by an independent third party and actual results may vary.

² These statements are “forward looking information”. Please refer to the Forward Information Advisory on page two of this Presentation.

Comparison of Beneficiation Methods

Metric	Flotation (Wet Circuit) ¹	Air Classification (Dry Circuit) ^{2,4}
 Purity	 80-98%	 90-95% (anticipated) ^{1,3}
 Energy Use	 14 kWh/tonne of Ore ¹	 9 kWh/tonne of Ore
 Logistical Complexity	<ul style="list-style-type: none">  Potentially high complexity due to hazardous processes  High cost to manage wet circuit  Drying Required 	<ul style="list-style-type: none">  No direct water usage during purification  No drying required  Management believes Quarry operation possible
 By-Products	<ul style="list-style-type: none">  Wet tailings  Chemical reagents 	<ul style="list-style-type: none">  Management believes by-products may supplement revenue (e.g. construction materials)

¹ “Estimates of Electricity Requirements for the Recovery of Mineral Commodities, with Examples Applied to Sub-Saharan Africa.” USGS (2011)

² The Company’s Air Classification (Dry Circuit) remains in the research and development phase

³ Management anticipates that 98% purity is possible with the inclusion of additional processes that are not yet proven or commercialized. Estimates and results are based on laboratory tests only and such results or estimates, as applicable, may not be replicated, scaled or result in the same estimates, measurements, or results in commercial utilizations. Estimates or results have not been verified by an independent third party and actual results may vary. ⁴ This slide contains “forward looking information”. Please refer to the Forward Information Advisory on page two of this Presentation.

Air Classifier Development Plan



	Q1 2023	Q2 2023	Q3 2023	Q4 2023	Q1 2024	Q2 2024	Q3 2024	Q4 2024
Finish Development of Prototype								
Testing of Graphite Ore								
Commence Production Design								
Fabrication of Production Air Classifier								
Product Testing and Validation								
Product Readiness								

- Management believes Volt has the current capability to determine feasibility of graphite ore bodies using the prototype air classifier
- Production Machine planned availability in 2 years ¹

Lochabar Property - 9 Mining Claims

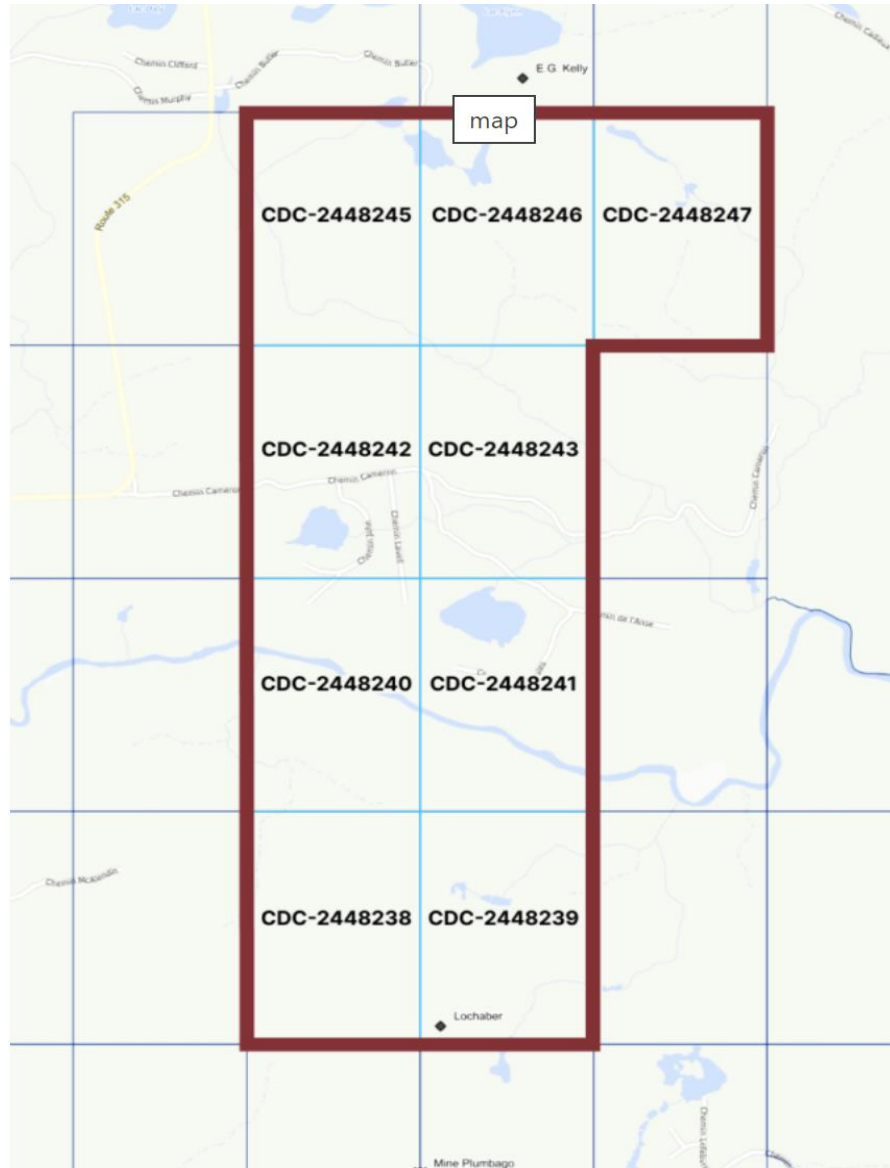

- **43-101 Technical report** was completed for entire property conducted by SRK Consulting in 2015. Approximately 40% of this deposit is located on Volt's Claims. The remaining deposit trends south.
- Volt's mining claims are located on the north portion of the Plumbago Mine
- Note: The aforementioned report is a historical estimate. Please see risks assumptions on the next page pertaining to historical estimates

Lochabar-Disclosure of Historical Estimate



MINERAL RESOURCES DISCLOSURE INFORMATION - Lochabar

The forgoing slide number 14 contains mineral resources disclosure information within the meaning of applicable securities laws. The mineral resource statements in this Investor Presentation include but are not limited to statements with respect to: the existence of sources of **Graphite**, the Company’s mineral permit holdings in **Quebec**, the historical concentrations of **Graphite** in the Company’s project areas (the “**Historical Estimate**”).

A qualified person has not done sufficient work to classify this historical estimate as current mineral resources or mineral reserves and the Company is not treating the historical estimate as current mineral resources or mineral reserves. The historical estimates should not be relied upon and there can be no assurance that any of the mineralization, in whole or part, will ever become economically viable.

Source and date of the Historical Estimate (including the existing technical report, if any)	The Resource estimate generated by w SRK Consulting (Canada) Inc. (SRK Project Number 5CG012.000) <u>July 31, 2015</u> . Authored By Sébastien Bernier, P. Geo., Dominic Chartier, P. Geo., and Ernest <u>Burga</u> , P. Eng.
Relevance and reliability of Historical Estimate	Volt acquired the property in 2018 consisting of 37 claims which subsequently expired. In 2021 Volt reclaimed 9 of 30 claims at the location of the mineral deposit. It is estimated that approximately on 40% of the resource occurs on Volt’s mining claims.
Key assumptions, parameters, and methods used to prepare the Historical Estimate	This report is based on extensive work performed by Rock Tech which include grab samples, trenching and 37 boreholes (6,981 metres of drilling). Between 2012-2014 A total of 3,730 samples (3,629 metres) was collected by Rock Tech for assaying. In addition, Great Lakes graphite who took this property on in 2014 collected an additional 499 samples (485 metres) from the 2012 drilling program in 20 of the 37 boreholes. The graphite bearing zones were typically sampled at 1-metre intervals. The historic 43-101 is based on these samples.
Resource categories used (see CIM Definition Standards on Mineral Resources and Mineral Reserves)	The resource categories are indicated mineral resource and inferred mineral resource.
More recent estimates or data available	In May of 2021 Volts collect airborne survey data on the property. Since <u>then</u> no further work has been performed on the property.
Work that needs to be done to upgrade or verify the historical estimate as current mineral resources or mineral reserves	An independent Qualified Person will be required to review and validate the historical data and historical estimates and compile an updated current Technical Report in accordance with NI 43-101.

Red Bird Property - 3 Mining Claims

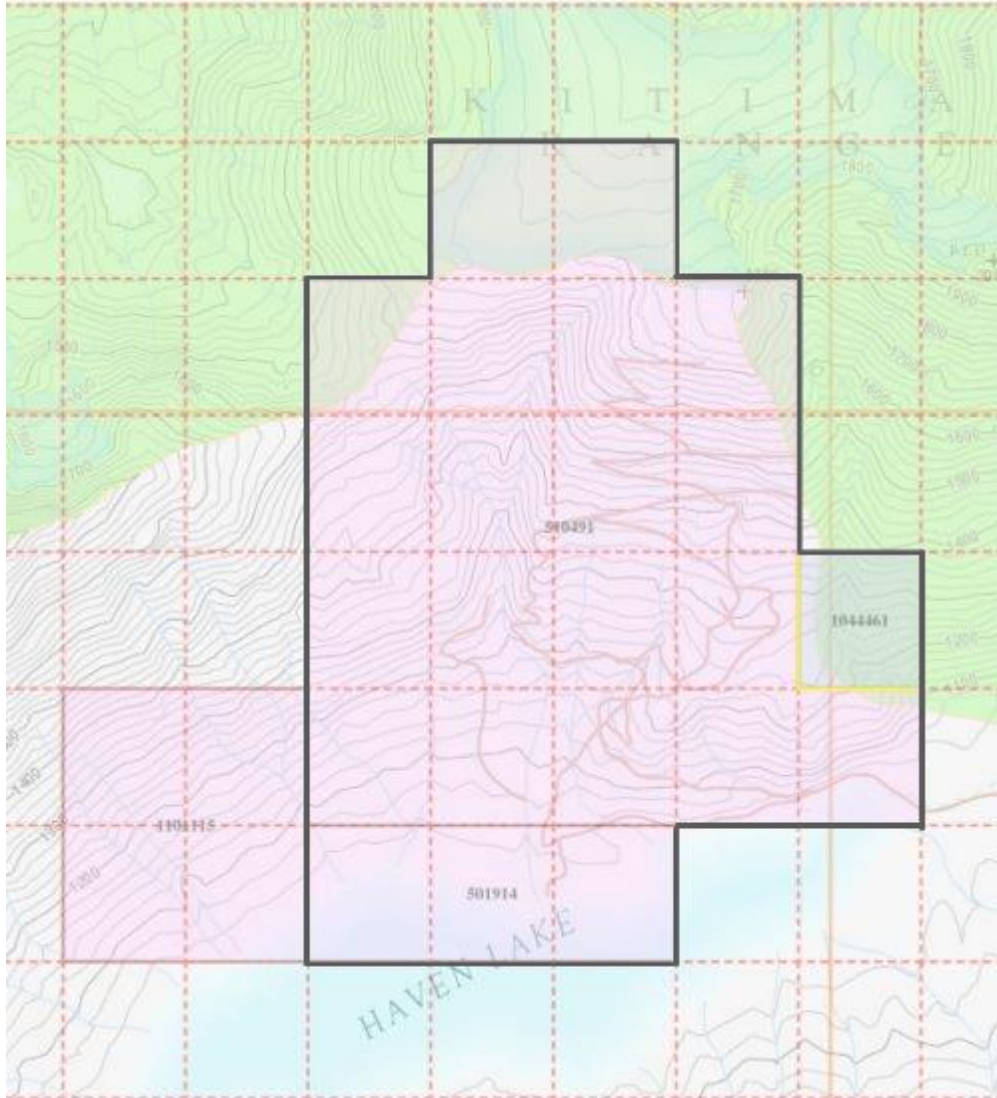

- Historical Estimate: 43-101 Technical report** was completed by G.H. Giroux, P.Eng. who visited the property in August 2007. A 2007 drill campaign resulted in a 103% increase in indicated tonnes at slightly lower grade at a 0.03% Mo cutoff. The total resource (indicated and inferred) in the Technical Report was estimated at 195.5 million lbs of Molybdenum. Note: The aforementioned report is a historical estimate. Please see risks assumptions on the next page pertaining to historical estimates

Summary of Red Bird Resource Estimates

Resource at 0.03 % Mo Cutoff	Indicated Resource			Inferred Resource		
	Tonnes		Mo	Tonnes		Mo
	(millions)	Mo (%)	(million lbs)	(millions)	Mo (%)	(million lbs)
2005 Resource May 26, 2006 Report				75.3	0.065	107.9
2006 Resource Aug. 23, 2007 Report	43.3	0.064	61.2	70.5	0.058	90.1
2007 Resource Dec. 20, 2007 Report	88.2	0.061	118.6	63.4	0.055	76.9

Red Bird-Disclosure of Historical Estimate



MINERAL RESOURCES DISCLOSURE INFORMATION - RED BIRD

The forgoing slide number 16 contains mineral resources disclosure information within the meaning of applicable securities laws. The mineral resource statements in this Investor Presentation include but are not limited to statements with respect to: the existence of sources of **molybdenum** the Company’s mineral permit holdings in **British Columbia**, the historical concentrations of **molybdenum** in the Company’s project areas (the “**Historical Estimate**”).

A qualified person has not done sufficient work to classify this historical estimate as current mineral resources or mineral reserves and the Company is not treating the historical estimate as current mineral resources or mineral reserves. The historical estimates should not be relied upon and there can be no assurance that any of the mineralization, in whole or part, will ever become economically viable.

Source and date of the Historical Estimate (including the existing technical report, if any)	The Resource estimate was last updated on Jan 11, 2008, by G.H. Giroux, P.Eng., MASC. from Giroux Consultants Ltd.
Relevance and reliability of Historical Estimate	Management understands that no development has taken place since the date of the report which at the time was owned by Volt (formerly Torch River Resources). The claims titles and locations have been verified by Volt.
Key assumptions, parameters, and methods used to prepare the Historical Estimate	This report is based on a review and digital compilation of available historical data, including detailed diamond drill hole logs for 57 holes completed by Craigmont Mines Ltd. in 1979 and 1980. In addition to the historical data, in July of 2003, In July 2003, Andris Kikauka, P. Geo. on behalf of Fundamental Resources Limited visited Red Bird and sampled 101 metres of drill core from holes 79-95 and 79-96 (Kikauka, 2004). A total of 21 samples (all 5 metre lengths except one 1 metre length) were submitted for 47 element ICP analysis. During the 2006 field season Scott Geophysics Ltd. complete a limited Induced Polarization (IP) study and Magnetometer survey on the Red Bird Property (Scott, 2006). A total of 6.7 km of IP and Magnetometer survey was completed on six north-south lines. Also during the 2006 field season soil Geochem samples were taken at 50 m spacing along the lines used for the geophysical surveys. A total of 143 soil samples were collected and run for 30 element ICP. The results from the 2005 re-sampling of historic drill core and 2006 drill programs resulted in a the development of the Historical 43-101.
Resource categories used (see CIM Definition Standards on Mineral Resources and Mineral Reserves)	The resource categories are indicated mineral resource and inferred mineral resource.
More recent estimates or data available	No further work has been performed since the Historic 43-101.
Work that needs to be done to upgrade or verify the historical estimate as current mineral resources or mineral reserves	An independent Qualified Person will be required to review and validate the historical data and historical estimates and compile an updated current Technical Report in accordance with NI 43-101.

Mount Copeland Property - 2 Mining Claims

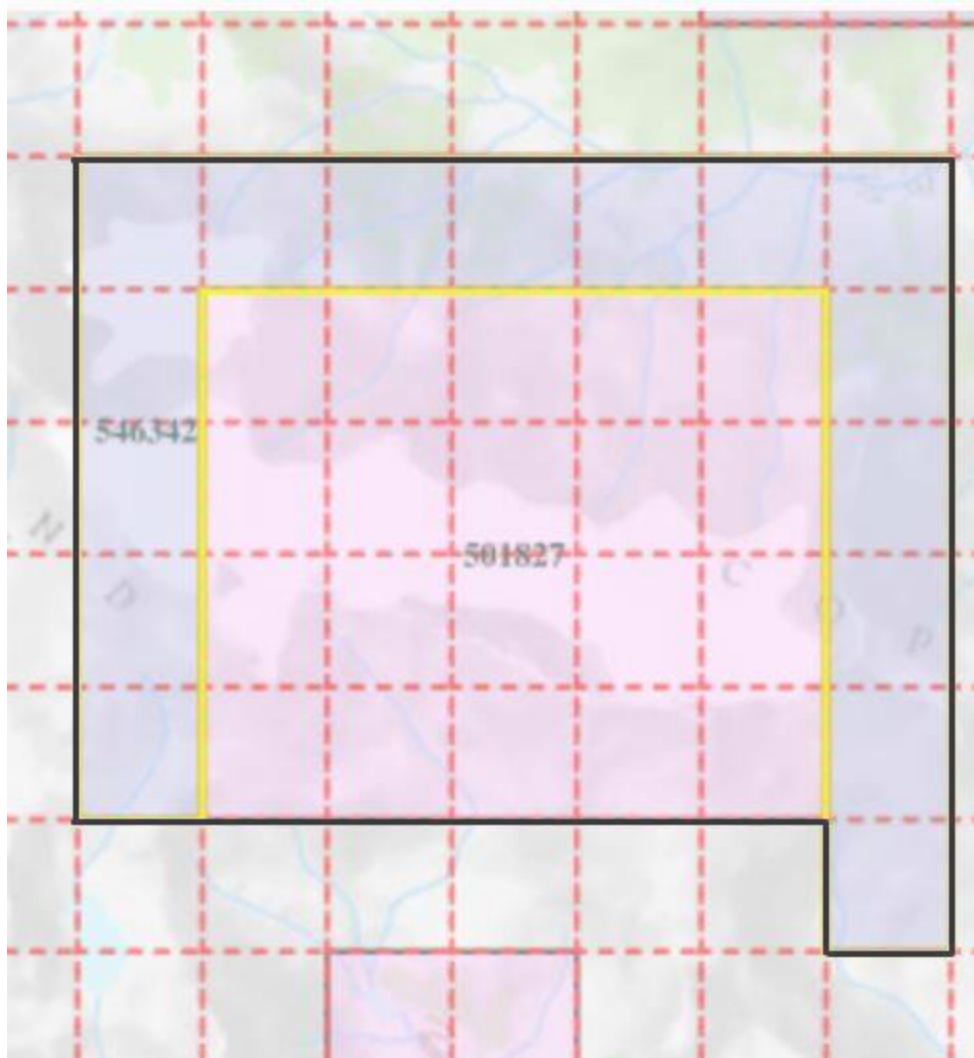

- From 1970 to 1973, the mine produced a total of 1,190,713 kilograms of molybdenum¹.
- In addition to molybdenum findings, Geochemical analysis of a total of 10 rock chip samples taken from a 15 m long outcrop identified rare earth element targets on Volt's mineral tenures².
- Elevated values of cerium, lanthanum, praseodymium, dysprosium, gadolinium, samarium, europium, thorium, zirconium, strontium occur in 5 of the 10 rock chip samples which are listed in the following table:

sample no	ppm Ce	ppm La	ppm Nd	ppm Pr	ppm Sm	ppm Dy	ppm Gd	ppm Eu	ppm Th	ppm Zr	ppm Sr
804	2220	1650	432	155	59.3	42.8	48.1	16.3	407	291	476
805	2120	1740	339	133	40.9	34.1	33.7	11	405	113	629
808	3440	2790	552	218	65.6	64.2	57.2	18.3	575	164	290
809	1820	1540	277	112	31.5	25.6	25.1	7.84	527	149	1449
810	2920	2690	389	168	41.6	33.9	33.8	10.5	351	81	1028

NOTE- all rock chip samples represent a true width of 0.5 m.

Manitouwadge Property - 5 Blocks of Claims

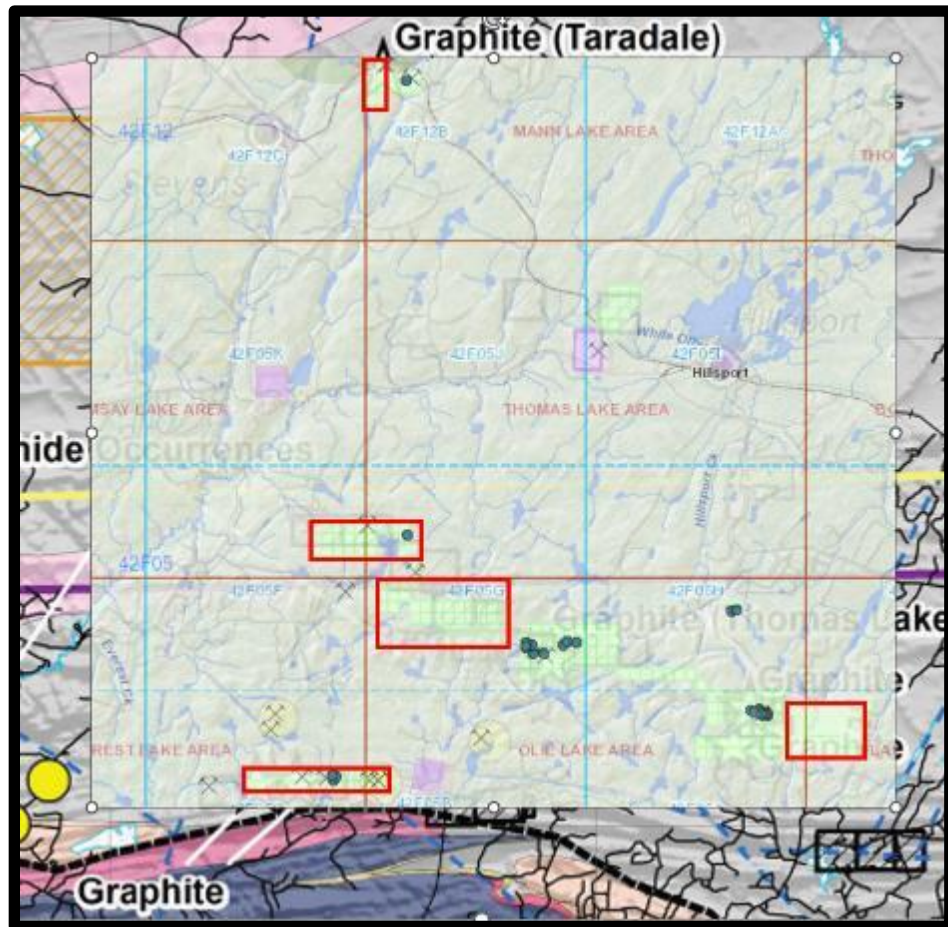

- Mining claims consists of 5 blocks of cells located in two general areas north of Manitouwadge. The first location consists of 4 blocks of claims and is approximately 28 km north of Manitouwadge um.
- The southern most claim in this area covers prospective extensions of known flake graphite occurrences identified by the Ontario Ministry of Northern Development. The new claims overlap older legacy claims which were previously known^{1,2,3,4} to have graphite occurrences. Volt Carbon's claims are adjacent to an existing graphite property owned by Ardiden Inc, which is known to have a developed prospect.

1, Ministry of Northern Development, Mines, Natural Resources and Forestry Recommendations for Exploration Special Edition: Critical Minerals Compilation 2020-2022,
2, McKay 1994. Mineral occurrences of the Manitouwadge area, volumes 1-3; Ontario Geological Survey, Open File Report 5906, 566p. 31112296
3, Ontario Mineral Inventory, MDI142F12SE00007, Taradale Graphite Occurrence - 1991
4, Technical Report on the Manitouwadge Graphite Exploration Property at Manitouwadge, Ontario, Canada. Felix, 2012

Abamasagi Lake Lithium Property

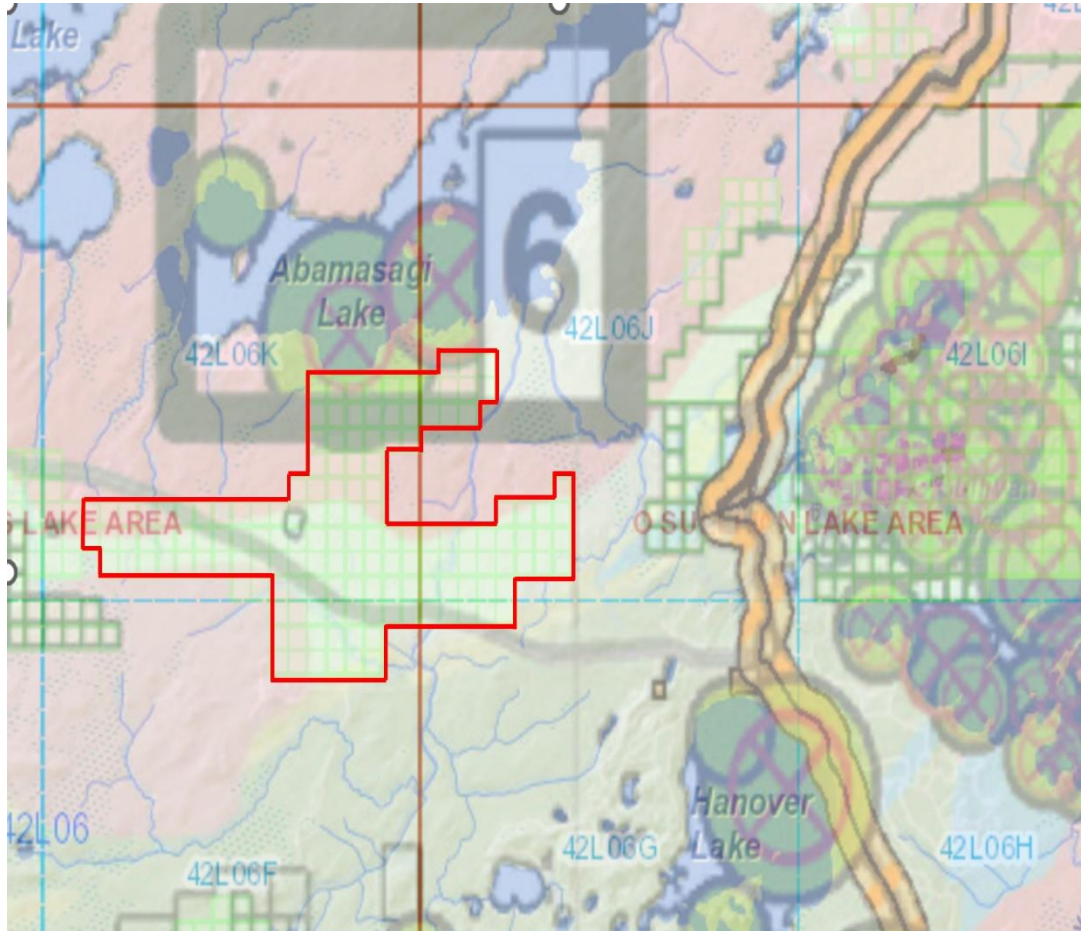

- A total of 150 Mining Claim located northwest of Nakina, Ontario, Canada. The staked property lies within the English River Subprovince and north of the contact with the Caribou Lake greenstone belt and is centred on Abamasagi Lake
- The area outlined in red and was staked by Volt Carbon. The map provided by the OMND¹ publication showed 98th percentile deep sediment samplings of lithium and cesium anomalies in Abamasagi Lake near the areas staked by Volt Carbon. In nearby areas, Fertile peraluminous granite units are well exposed on glacially polished surfaces indicating potential rare-element mineralizations.



Solid UltraBattery INC.

Developing the Next
Generation of Energy Storage
Systems



Progression of Battery Technology

Generation	Gen 0 1990s	Gen 1 (Present) 2010s	Gen 2 2020s	Gen 3 2025 onwards
Configuration	<div style="display: flex; flex-direction: column; align-items: center; border: 1px solid black; padding: 5px;"> <div style="background-color: #cccccc; padding: 5px; margin-bottom: 2px;">Thick Li-Metal</div> <div style="background-color: #1a2b3d; color: white; padding: 5px; margin-bottom: 2px;">Separator</div> <div style="background-color: #666666; padding: 5px;">Cathode (TiS₂)</div> </div>	<div style="display: flex; flex-direction: column; align-items: center; border: 1px solid black; padding: 5px;"> <div style="background-color: #cccccc; padding: 5px; margin-bottom: 2px;">Carbon Anode</div> <div style="background-color: #1a2b3d; color: white; padding: 5px; margin-bottom: 2px;">Separator</div> <div style="background-color: #666666; padding: 5px;">Cathode (LCO, LFP, NMC)</div> </div>	<div style="display: flex; flex-direction: column; align-items: center; border: 1px solid black; padding: 5px;"> <div style="background-color: #cccccc; padding: 5px; margin-bottom: 2px;">Si-composite Anode</div> <div style="background-color: #1a2b3d; color: white; padding: 5px; margin-bottom: 2px;">Separator</div> <div style="background-color: #666666; padding: 5px;">Cathode (NMC, NCA)</div> </div>	<div style="display: flex; flex-direction: column; align-items: center; border: 1px solid black; padding: 5px;"> <div style="background-color: #c0c080; padding: 5px; margin-bottom: 2px;">Thin Li-Metal</div> <div style="background-color: #1a2b3d; color: white; padding: 5px; margin-bottom: 2px;">Separator/Electrolyte</div> <div style="background-color: #666666; padding: 5px;">Cathode (NMC, S)</div> </div>
Type	Li-Metal	Li-ion	Li-ion	Li-Metal
Energy Density	100-200 Wh/kg	200-250 Wh/kg	250-300 Wh/kg	300-500 Wh/kg
	200-300 Wh/L	600 Wh/L	700 Wh/L	1200 Wh/L
Safety	Dangerous	More Safe	Safer	Safer



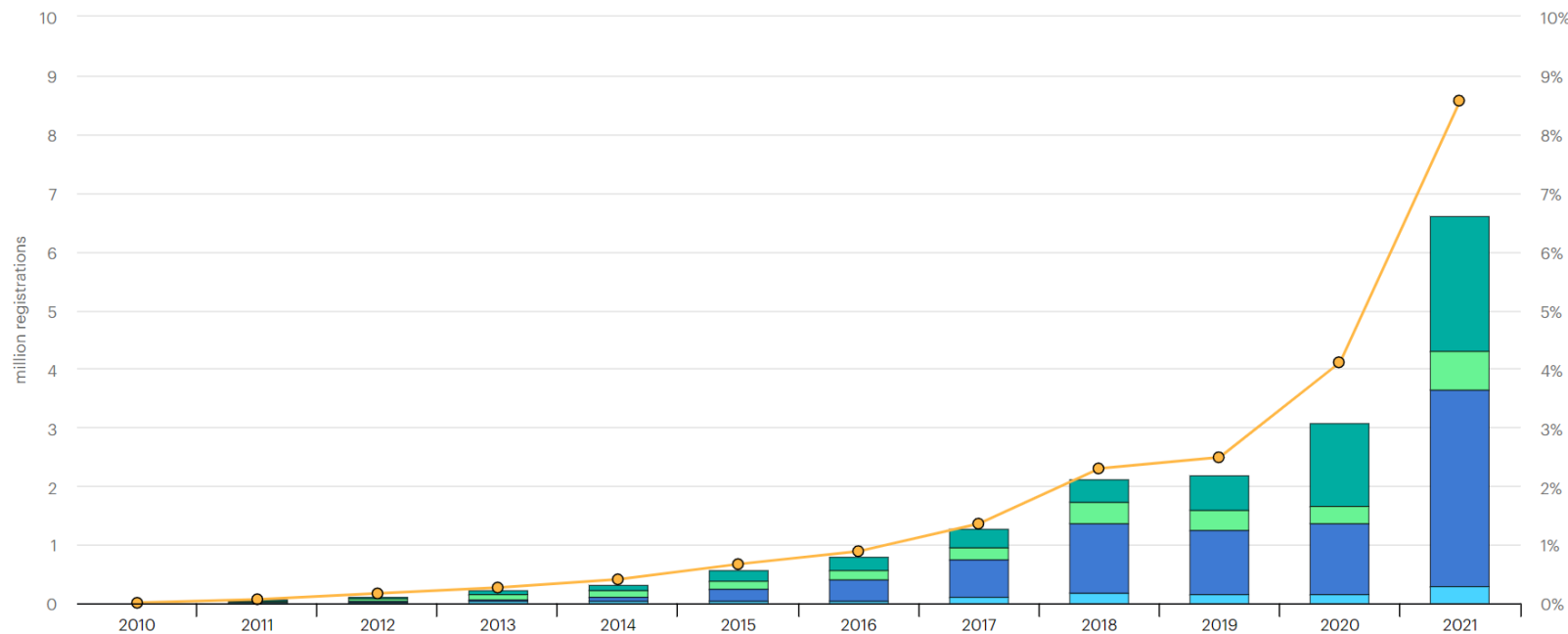

Automotive Application: EV Adoption

- Sales of electric cars hit 6.6 million in 2021, more than tripling their market share from two years earlier ¹
- Management believes that the accelerated mass-adoption of electric cars will require further battery innovation^{2, 3}

Global sales and sales market share of electric cars, 2010-2021



Customer Requirements for Mass Market Adoption

-  **Energy / Capacity**
>300 mile range
-  **Fast Charging**
Charge in <15 min
-  **Cost**
< \$30K, 300 mile EVs
-  **Battery Lifetime**
>12 years, >150k miles
-  **Safety**
Solid, non-oxidizable separator

Source: International Energy Agency, 2022¹

¹ Source: <https://www.iea.org/commentaries/electric-cars-fend-off-supply-challenges-to-more-than-double-global-sales>

² Source: <https://www.quantumscape.com/wp-content/uploads/2021/10/Data-Launch-Updated-Post-Presentation-20210107-2.pdf>

³ These statements are “forward looking information”. Please refer to the Forward Information Advisory on page two of this Presentation.

Solid State Lithium Metal Batteries

- ❑ Volt Carbon Technologies is developing its patent-pending solid-state battery (SSB) technology through its subsidiary, Solid Ultrabattery
- ❑ The technology uses a solid electrolyte separator (resulting in lower weight and higher energy density)
- ❑ The solid electrolyte separator is adjacent to a lithium metal current collector
- ❑ Compared to current generation lithium-ion batteries, Management believes that these SSBs have: ¹
 - Lower carbon footprint
 - Higher recyclability
 - Reduced manufacturing complexity
- ❑ Management proposes this technology has potential for disruption in the following industries: ¹
 - Automotive
 - Aerospace
 - Consumer electronics

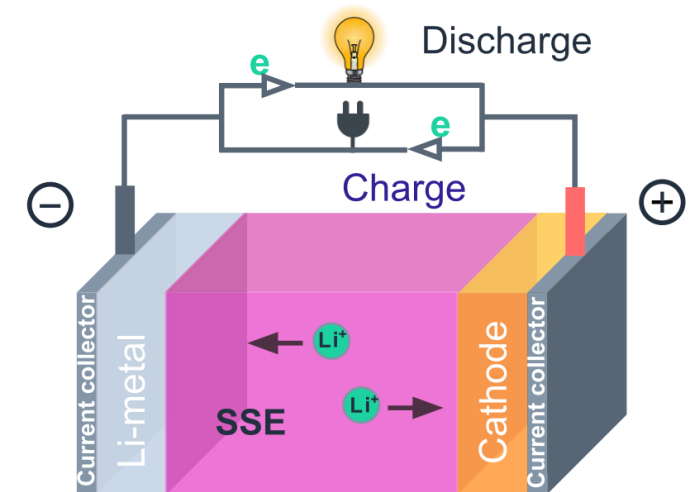

Prior Results Pre 2022 (Lithium Iron Phosphate)

- Coin cells were made using Solid Ultrabattery's proprietary solid electrolyte
- The Company tested over 3000 charge/discharge cycles
- Cells maintained capacity retention of 80%¹

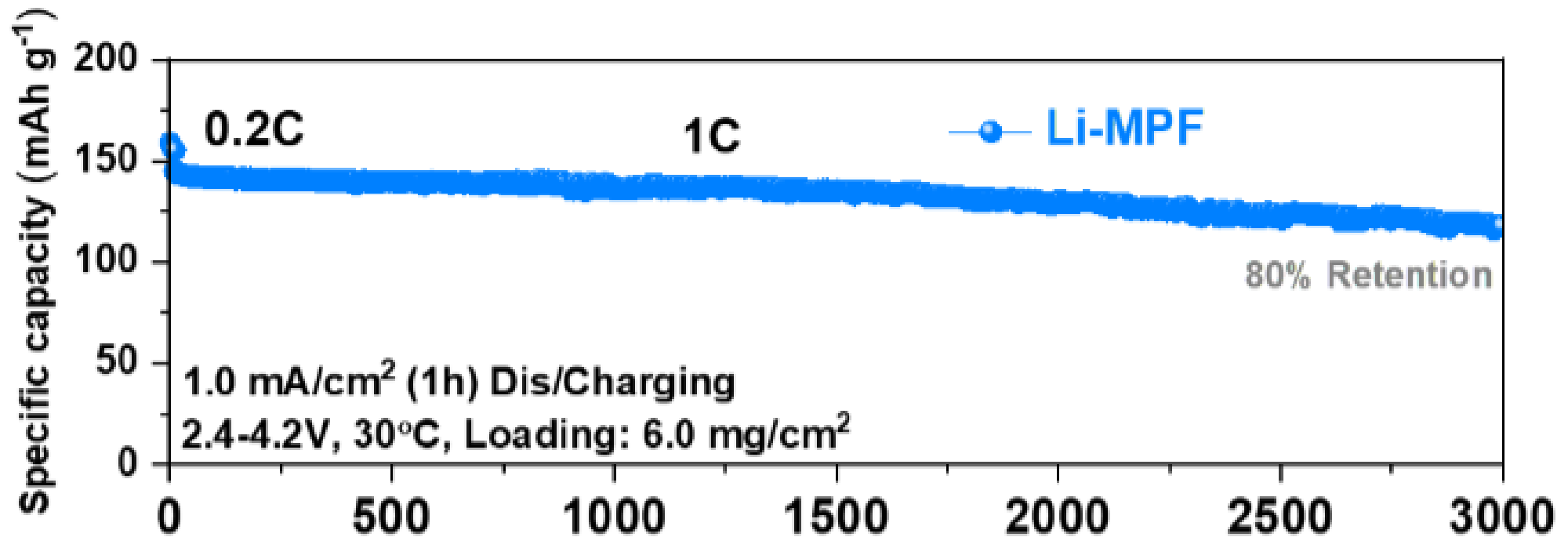

Fig. 2: NMC811 Lithium Metal Pouch Cell, Charge/Discharge data, C/3, 25 °C

2022 Results (NMC 811 Cathode)

- 400 cycles (coin cell) and 300 cycles (pouch cell) over the 80% retention capacity have been achieved in 2022.¹

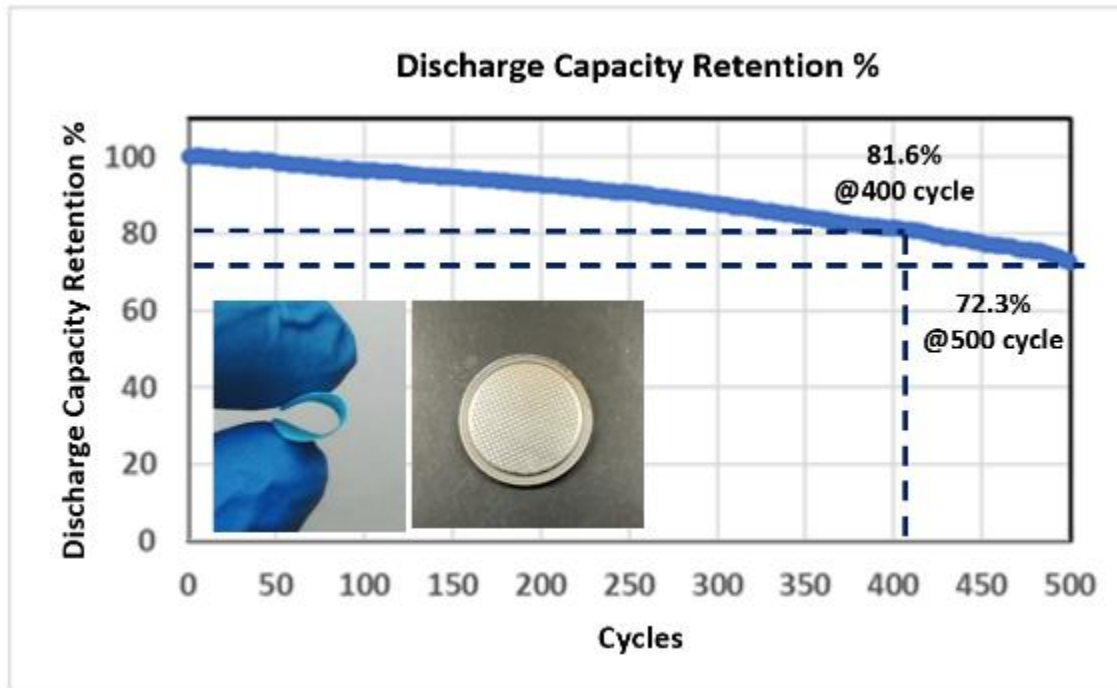

Fig. 1: NMC811 Lithium Metal Coin Cell, Charge/Discharge data, C/3, 25 °C

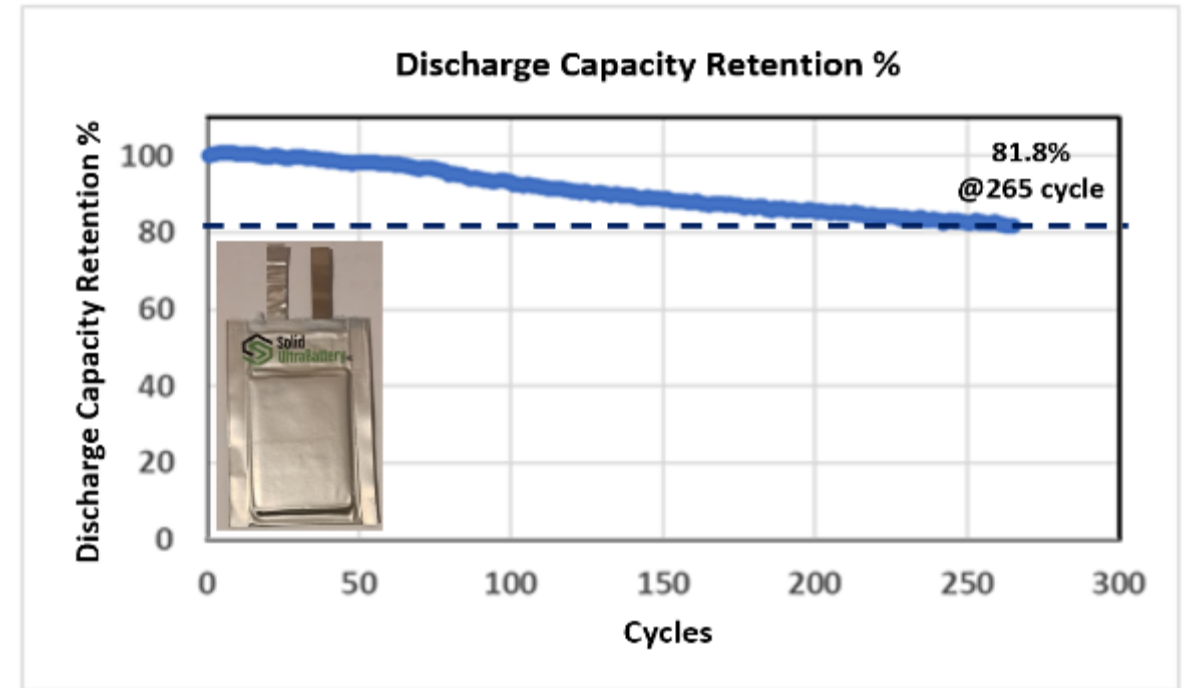

Fig. 2: NMC811 Lithium Metal Pouch Cell, Charge/Discharge data, C/3, 25 °C

¹ Estimates and results are based on laboratory tests only and such results or estimates, as applicable, may not be replicated, scaled or result in the same estimates, measurements, or results in commercial utilizations. Estimates or results have not been verified by an independent third party and actual results may vary.

Battery R&D Center







- Leased a new 10,000 ft² facility located at 590 Hanlon Creek Blvd. in Guelph, Ontario
- Construction completed in Dec. 2021
- Complete Prototype battery laboratory and cell assembly line
- Currently producing small batch runs of coin cells and pouch cells

Solid Ultrabattery Team



SOLID ULTRABATTERY
8 LAYER POUCH CELL

Comparison of Solid UltraBattery and Leading Listed Competitor

Performance Requirements		Leading Competitor		Our Technology ¹
 Charge Rate	✓	4C fast charge (<15 min)	✓✓	5C fast charge (<10 min)
 Cycle Life	✓	>800 cycles	✓✓	>1000 cycles
 Energy	✓	350-450 Wh/kg	✓	350-450 Wh/kg
 Cost	✗	Higher cost (inorganic SSE)	✓	Lower cost (composite SSE)

24 Month Outlook

- 350Wh/kg of energy density with 500 cycles aimed be achieved in 2023. ¹
- The target is anticipated be comparable to leading competitors in lithium metal batteries.

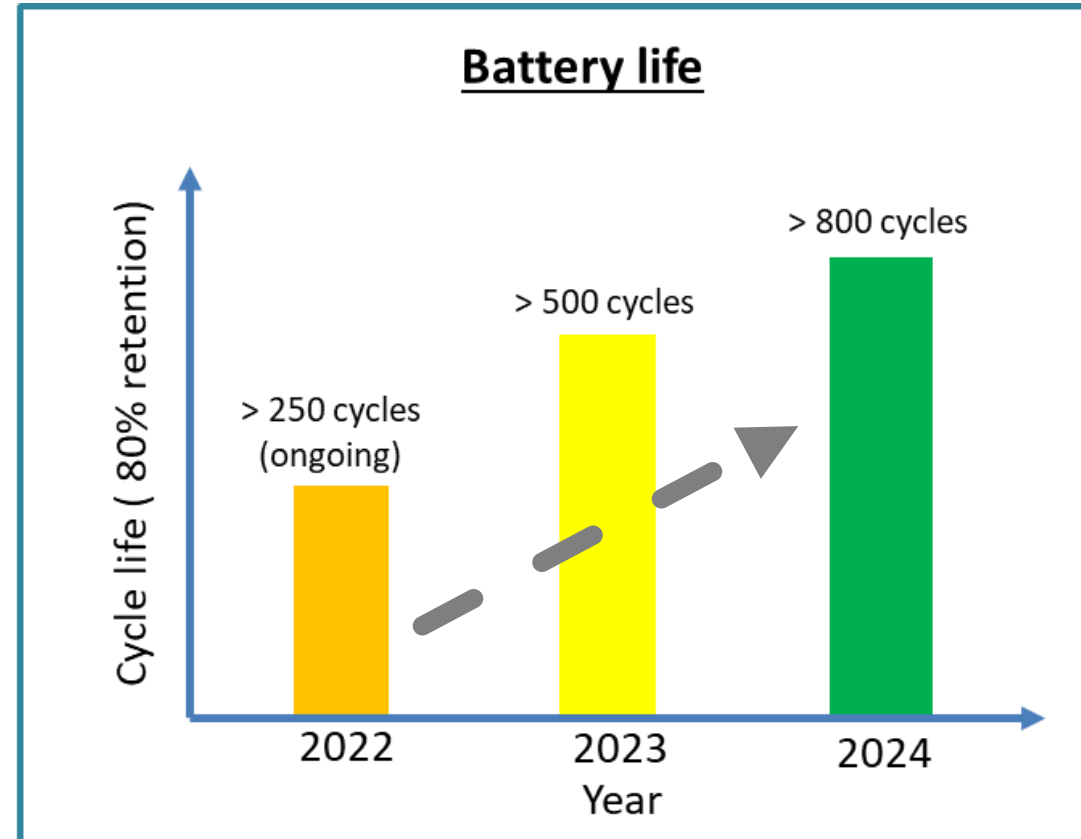
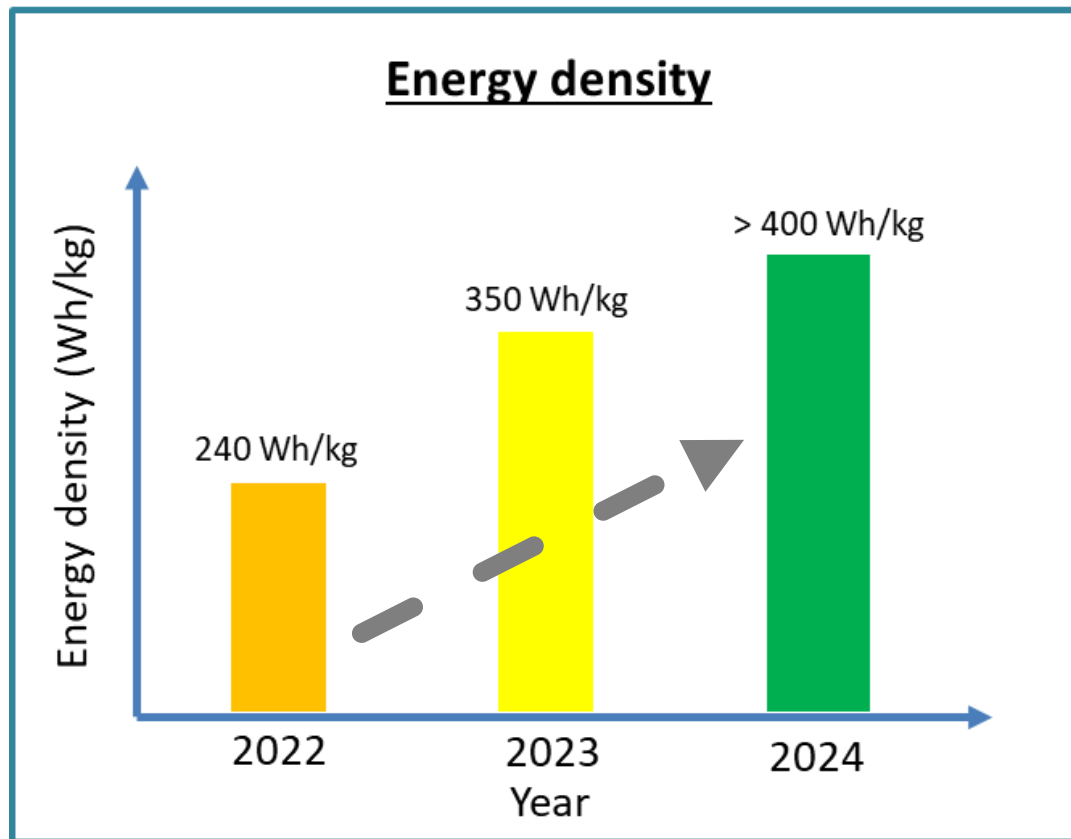
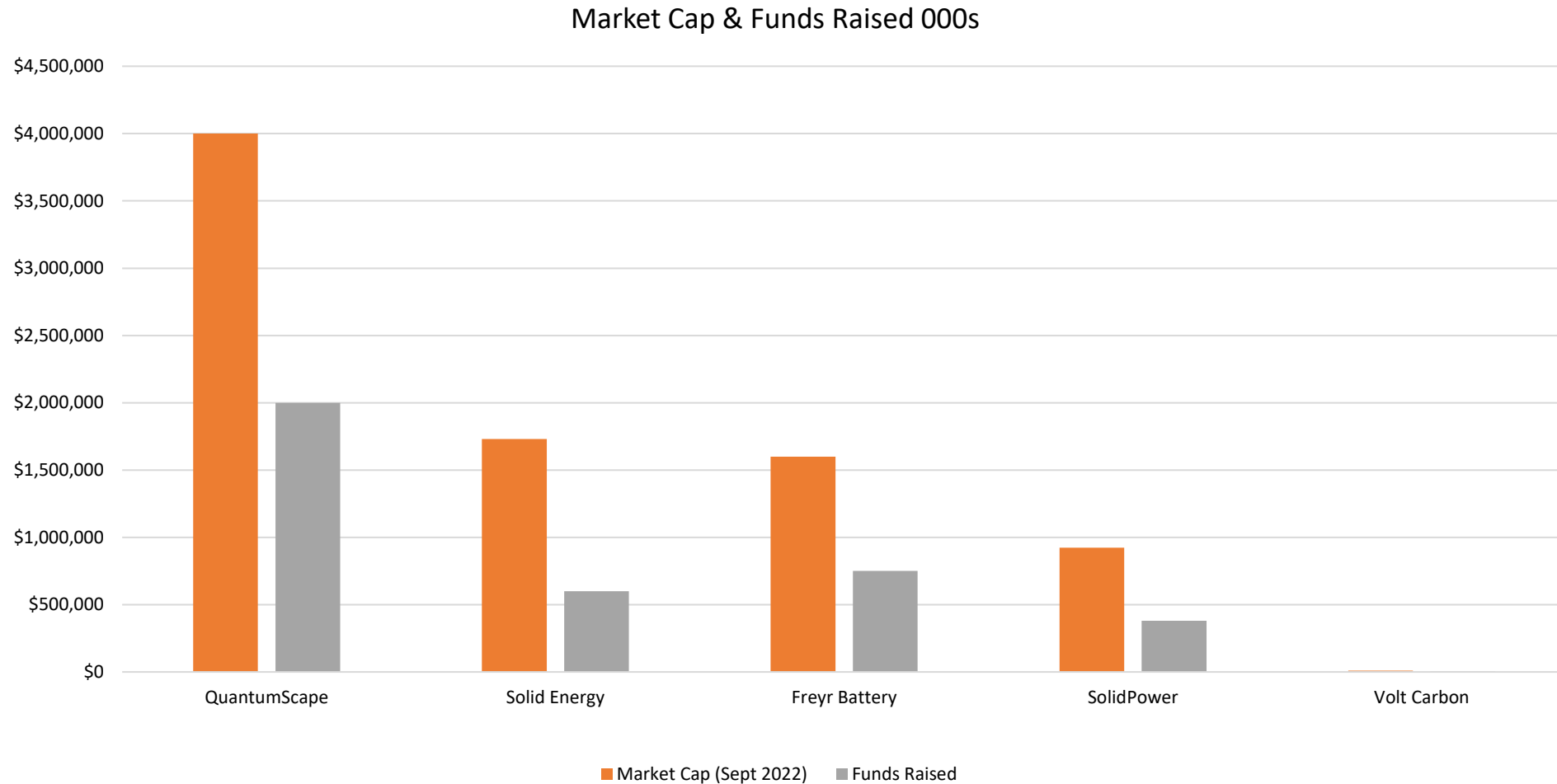

Fig. 2: NMC811 Lithium Metal Pouch Cell, Charge/Discharge data, C/3, 25 °C

1. These statements are “forward looking information”. Please refer to the Forward Information Advisory on page two of this Presentation.

2. Estimates and results are based on laboratory tests only and such results or estimates, as applicable, may not be replicated, scaled or result in the same estimates, measurements, or results in commercial utilizations. Estimates or results have not been verified by an independent third party and actual results may vary.

Comparison to Peers Publicly Traded with Similar Technology



*Since Acquiring Solid Ultrabattery (SUB) Volt has raised 4.0M Total, 2.0M has been expended for technology development at SUB, Management considers Volt's technology competitive with its peers. Volt's Market Cap on Sept 22, \$13M CDN

Near-Term Aero Application

- Management anticipates that the high energy-density of Solid Ultrabattery's lithium metal batteries are suitable for aerospace drone applications ^{1, 2}
- A sub-1 kg class gram electric aircraft is anticipated to be tested with Solid Ultrabattery technology with the following goals:
 - Endurance flights of up to 12 hours with solar battery electric power
 - Simultaneously power a high-resolution camera and an infrared camera for surveillance: aerial imagery and data capture
 - Batteries are anticipated to support data and video transmission over 60 km via mesh network communication relaying between aircraft

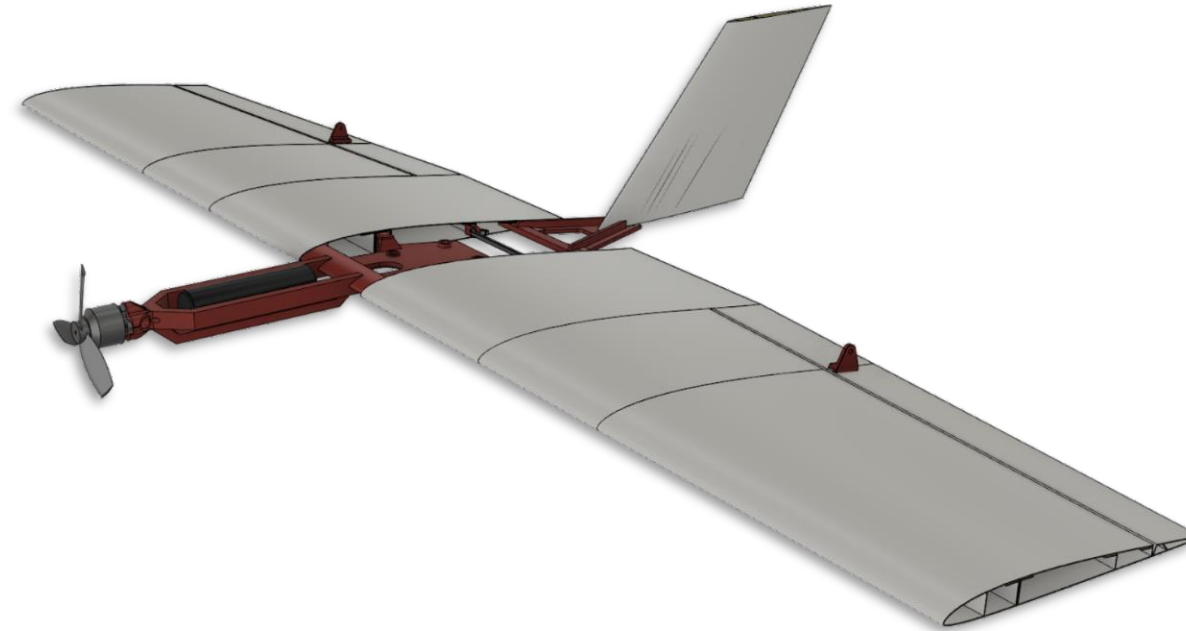

1. These statements are “forward looking information”. Please refer to the Forward Information Advisory on page two of this Presentation.

2. Estimates and results are based on laboratory tests only and such results or estimates, as applicable, may not be replicated, scaled or result in the same estimates, measurements, or results in commercial utilizations. Estimates or results have not been verified by an independent third party and actual results may vary.

5 Year Plan for Battery Development

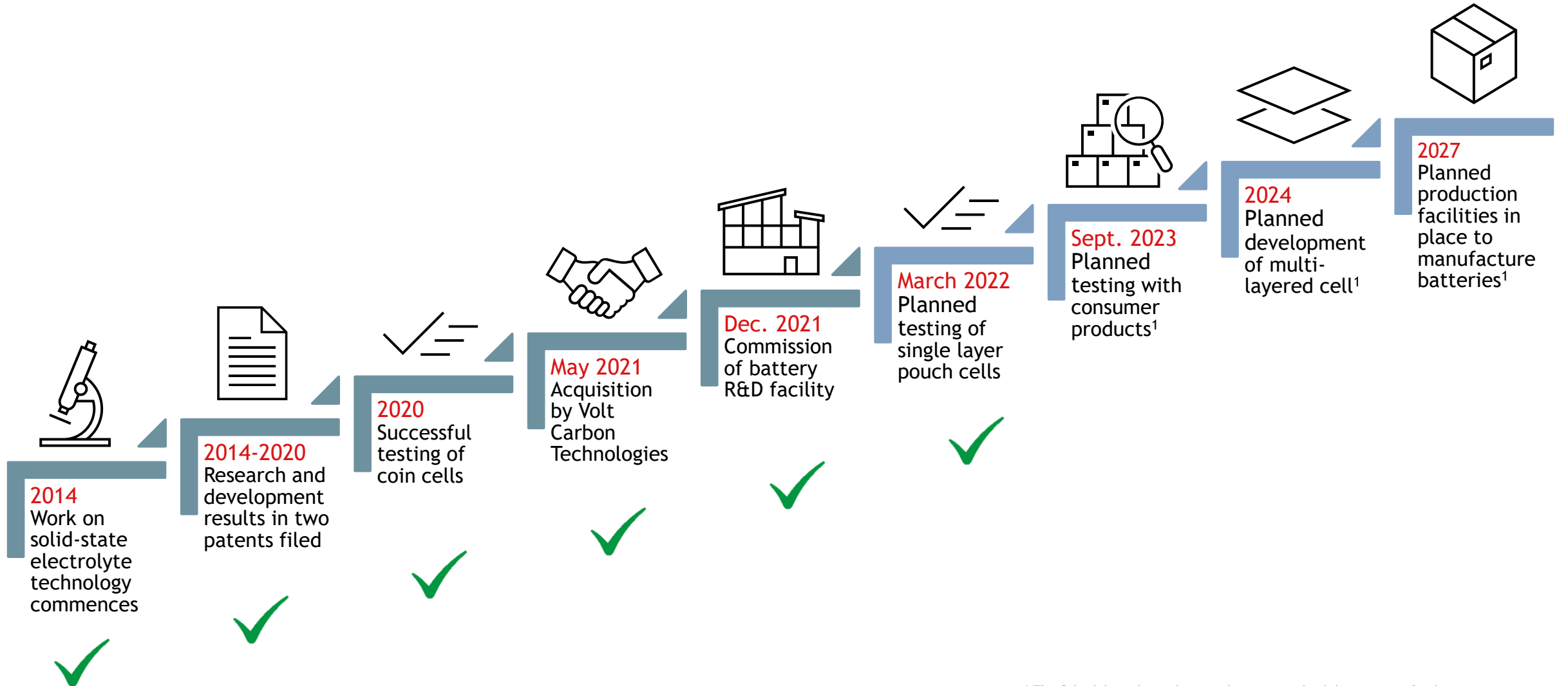

¹ The Schedule is dependent on the company's ability to raise funds

² Estimates and results are based on laboratory tests only and such results or estimates, as applicable, may not be replicated, scaled or result in the same estimates, measurements, or results in commercial utilizations. Estimates or results have not been verified by an independent third party and actual results may vary.

Governance

Board of Directors



V-Bond Lee
CEO & Director,
Chairman of the Board



Robert Martin
Director



Zhongwei (Wei) Chen
Director



Dr. David W Madill, M.D
Interim CFO & Director



Glen Nursey
Director

Core Leadership Team Bios



V-Bond Lee

CEO, Director, Chairman of the Board

V-Bond is a Professional Engineer with 30+ years of leading-edge product development and engineering management. He has successfully developed and commercialized new groundbreaking methods and technologies for various companies; including BionX International (VP of Engineering & CTO), Sumitomo Precision Products (Director of Engineering), United Technologies Aerospace Systems (Project Head of Business Aircraft), General Electric (Director of Engineering), and Magna International (Engineering Manager).



Zhongwei (Wei) Chen

Director

Zhongwei (Wei) Chen, PhD, has been a professor in the department of Chemical Engineering at University of Waterloo for over 12 years. His Applied Nanomaterials & Clean Energy lab has pioneered solid electrolyte battery technology for Volt Carbon Technologies. He is recognized as the world leader in battery and fuel cell technology. He is author of over 380 scientific papers and holder of 30+ U.S./international patents/provisional patents.



Robert Martin

Director

Mr Martin is a successful businessman and accomplished company director with over 25 years' experience across a broad range of sectors including, mining and mining services, manufacturing and capital markets. Mr. Martin has a profound insight into corporate strategy, capital operation, management integration and business structures and efficiencies. Mr Martin now runs a family office in Western Australia with a focus on investing and supporting emerging private and public businesses Mr Martin currently holds the positions of Non-Executive Chairman of Publicly Listed Equinox Resources Limited (ASX: EQN) Non-Executive Chairman of Critical Resources Limited (ASX:CRR) Non-Executive Chairman for Battery Age Minerals Limited (ASX: BM8) and as Non-Executive Director of TSX-V listed Volt Carbon Technologies (TSX-V: VCT)

Share Structure

■ As of Dec 31, 2022, the Company has the following common shares, stock option and warrants outstanding:

- Common shares - 168,100,902
- Options - 9,680,000
- Share purchase warrants - 18,152,500

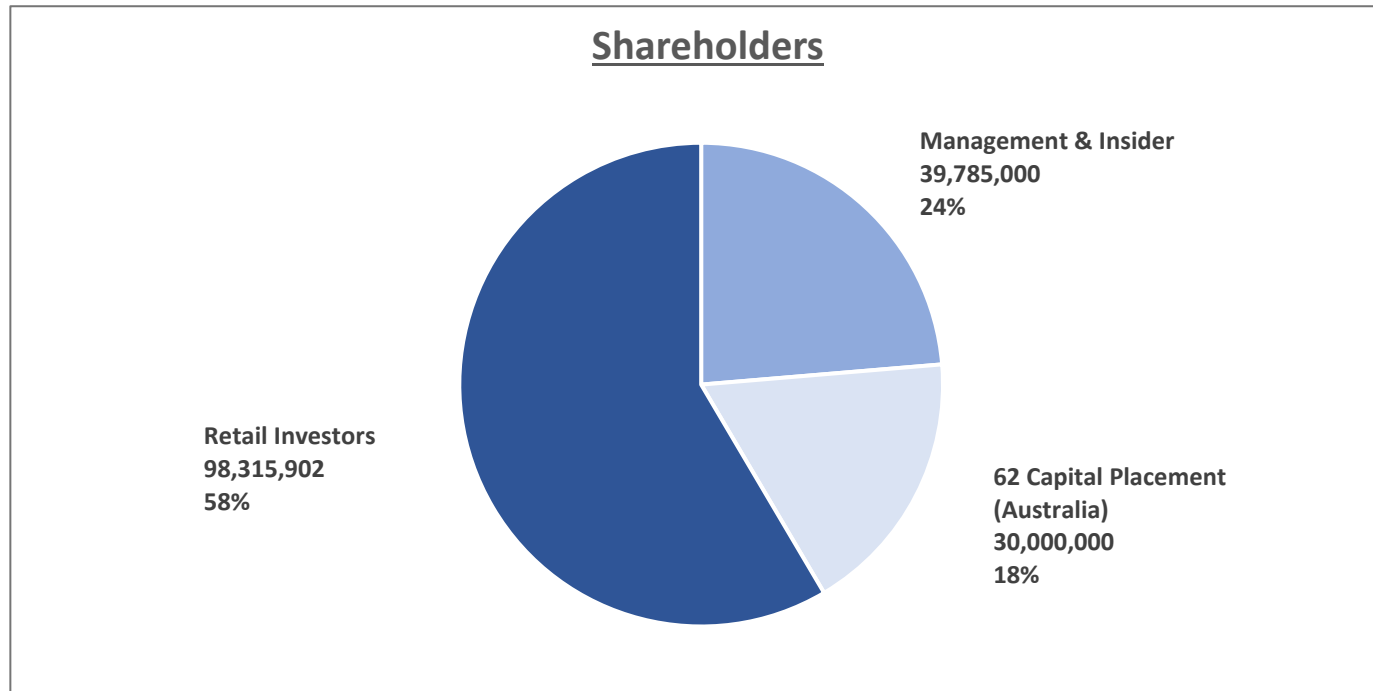

CANADIAN STATUTORY RIGHTS OF RESCISSION

Securities legislation in certain of the provinces of Canada provides purchasers with, in addition to any other rights they may have at law, a remedy for rescission or damages, or both, where this Investor Presentation contains a misrepresentation (as such term may be defined in the applicable legislation). However, those remedies, or notice with respect thereto, must be exercised or delivered, as the case may be, by the purchaser within the time limits prescribed in applicable legislation. Further, such rights may depend on the particular private placement exemption relied upon by the issuer. The following is a summary of the rights of rescission or to damages, or both, available to purchasers under the securities legislation of certain of the provinces of Canada or provided by contract. Each purchaser should refer to the provisions of the applicable legislation for the particulars of these rights or consult with a legal advisor.

Ontario

OSC Rule 45-501 provides that when a document deemed to be an offering memorandum, such as this Investor Presentation, is delivered to an investor to whom securities are distributed in reliance upon the accredited investor exemption or the minimum amount exemption in National Instrument 45-106, the right of action referred to in section 130.1 of the Securities Act (Ontario) ("Section 130.1") is applicable.

Section 130.1 provides purchasers who purchase securities offered by an offering memorandum with a statutory right of action against the issuer of securities for rescission or damages in the event that the offering memorandum contains a "misrepresentation", without regard to whether the purchaser relied on the misrepresentation.

General

The foregoing summaries are subject to the express provisions of the legislation described therein and the regulations and policy statements thereunder and reference is made thereto for the complete text of such provisions. The rights summarized above are in addition to and without derogation from any other rights or remedies available at law to an investor.

UNITED STATES

This Investor Presentation does not constitute an offer to sell, or a solicitation of an offer to buy, securities in the United States. Any such offer to sell or solicitation of an offer to buy the securities described herein or during the presentation will be made only pursuant to subscription documentation. Any such offering will be made in the United States in reliance upon an exemption from registration under the U.S. Securities Act of 1933, as amended (the "U.S. Securities Act"), for an offer and sale of securities that does not involve a public offering, and the offer and sale of the securities will be conditioned on the receipt of representations, warranties and agreements of prospective purchasers to establish that exemption.

Any securities described in this Investor Presentation have not been, and will not be, registered under the U.S. Securities Act and may not be offered or sold in the United States except in transactions exempt from, or not subject to, registration under the U.S. Securities Act and applicable US state securities laws.

Accordingly the securities may not be resold, pledged, hypothecated or otherwise disposed of or transferred except in accordance with the registration requirements of the U.S. Securities Act and any applicable state securities laws or pursuant to an applicable exemption from such registration requirements of the U.S. Securities Act and any applicable state securities laws.

THE SECURITIES HAVE NOT BEEN APPROVED OR DISAPPROVED BY THE UNITED STATES SECURITIES AND EXCHANGE COMMISSION OR ANY STATE SECURITIES COMMISSION NOR HAS THE UNITED STATES SECURITIES AND EXCHANGE COMMISSION OR ANY STATE SECURITIES COMMISSION PASSED UPON THE ACCURACY OR ADEQUACY OF THIS COMMUNICATION. ANY REPRESENTATION TO THE CONTRARY IS A CRIMINAL OFFENSE.